

External Roll-a-Finish[®] tools

AEX series

For burnishing the outside diameter of cylindrical parts, such as shafts rotating in bushings or bearings. Provides an ideal surface for grease and oil seals.



AEX-1

Available from stock for nominal diameters from .062 to 2.000 inches (1.57 to 50.8mm)

Offered in *three styles*:

- **AEX-1**, with a smaller body diameter and shorter overall length suitable for screw machines and automatics. All AEX-1 tools are bottoming-style, designed for machine-feed. Available for nominal diameters from .062 to .625 inch (1.57 to 15.88mm).
- **AEX-2**, for nominal diameters from .062 to 1.000 inch (1.57 to 25.4mm). Features twice the work length as compared to the AEX-1. Available with machine-feeding cage or with bottoming-style cage.
- **AEX-3**, for nominal diameters from 1.000 to 2.000 inches (25.4 to 50.8mm). Available with machine-feeding cage or with bottoming-style cage.

AEX tools are adjustable in increments of .0001 inch (.002mm).



AEX-2



AEX-3

Standard tool specifications

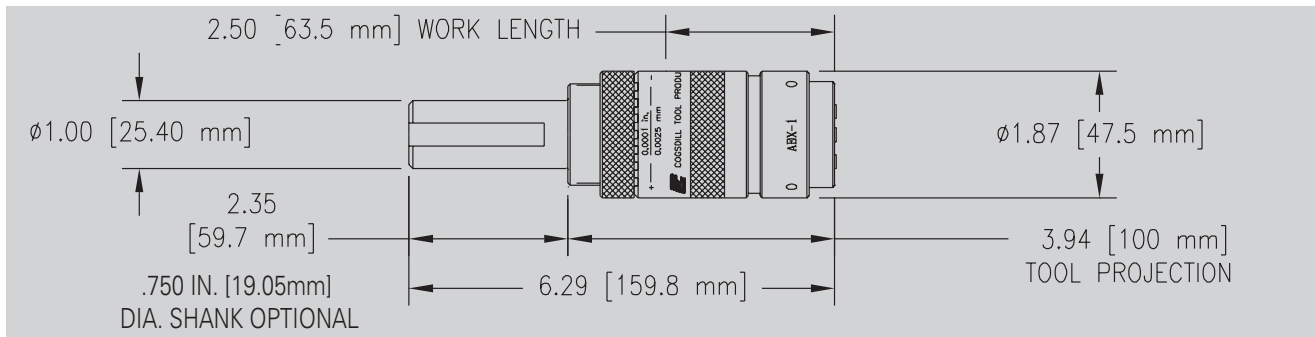

“AEX-1” SERIES ROLL-A-FINISH® TOOLS .062 TO .625 IN. (1.57 TO 15.88 MM)

DIAMETER RANGE		TOOL NUMBER
INCHES	MM	BOTTOMING (NO HELIX)
.043-.064	1.09-1.63	AEX-1-062
.059-.080	1.50-2.03	AEX-1-078
.075-.096	1.91-2.44	AEX-1-094
.090-.111	2.29-2.82	AEX-1-109
.106-.127	2.69-3.23	AEX-1-125
.122-.143	3.10-3.63	AEX-1-141
.137-.158	3.48-4.01	AEX-1-156
.152-.173	3.86-4.39	AEX-1-171
.168-.189	4.27-4.80	AEX-1-187
.184-.205	4.67-5.21	AEX-1-203
.200-.221	5.08-5.61	AEX-1-219
.215-.236	5.46-5.99	AEX-1-234
.231-.252	5.87-6.40	AEX-1-250
.247-.268	6.27-6.81	AEX-1-266
.262-.283	6.65-7.19	AEX-1-281
.278-.299	7.06-7.59	AEX-1-297
.293-.314	7.44-7.98	AEX-1-312
.309-.330	7.85-8.38	AEX-1-328
.325-.346	8.26-8.79	AEX-1-344
.340-.361	8.64-9.17	AEX-1-359
.356-.377	9.04-9.58	AEX-1-375
.372-.393	9.49-9.98	AEX-1-391
.387-.408	9.83-10.36	AEX-1-406
.403-.424	10.24-10.77	AEX-1-422
.418-.439	10.62-11.15	AEX-1-438
.434-.455	11.02-11.56	AEX-1-453
.450-.471	11.43-11.96	AEX-1-469
.465-.486	11.81-12.34	AEX-1-484
.481-.502	12.22-12.75	AEX-1-500
.497-.518	12.62-13.16	AEX-1-516
.512-.533	13.00-13.54	AEX-1-531
.528-.549	13.41-13.94	AEX-1-547
.543-.564	13.79-14.33	AEX-1-562
.559-.580	14.20-14.73	AEX-1-578
.575-.596	14.61-15.14	AEX-1-594
.590-.611	14.99-15.52	AEX-1-609
.606-.627	15.39-15.93	AEX-1-625

Shanks other than shown above are available upon request.

Standard tool specifications

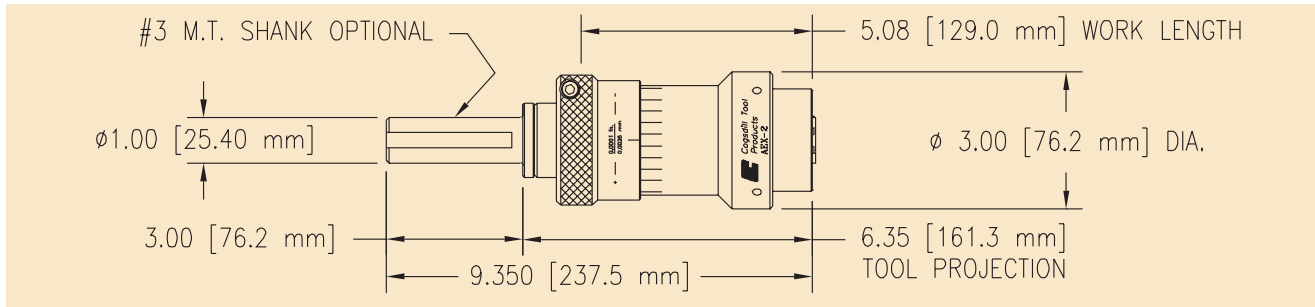

"AEX-2" SERIES ROLL-A-FINISH® TOOLS .062 TO 1.000 IN. (1.57 TO 25.4 MM)

DIAMETER RANGE		TOOL NUMBER	
INCHES	MM	MACHINE-FEED (NO HELIX)	BOTTOMING (NO HELIX)
.045-.066	1.14-1.68	AEX-2-062	AEXB-2-062
.061-.082	1.57-2.08	AEX-2-078	AEXB-2-078
.077-.098	1.96-2.49	AEX-2-094	AEXB-2-094
.092-.113	2.34-2.87	AEX-2-109	AEXB-2-109
.108-.129	2.74-3.28	AEX-2-125	AEXB-2-125
.124-.145	3.15-3.68	AEX-2-141	AEXB-2-141
.139-.160	3.53-4.06	AEX-2-156	AEXB-2-156
.154-.175	3.91-4.45	AEX-2-171	AEXB-2-171
.170-.191	4.32-4.85	AEX-2-187	AEXB-2-187
.186-.207	4.72-5.26	AEX-2-203	AEXB-2-203
.202-.223	5.13-5.66	AEX-2-219	AEXB-2-219
.217-.238	5.51-6.05	AEX-2-234	AEXB-2-234
.233-.254	5.92-6.45	AEX-2-250	AEXB-2-250
.249-.270	6.32-6.86	AEX-2-266	AEXB-2-266
.264-.285	6.71-7.24	AEX-2-281	AEXB-2-281
.280-.301	7.11-7.65	AEX-2-297	AEXB-2-297
.295-.316	7.49-8.03	AEX-2-312	AEXB-2-312
.311-.332	7.90-8.43	AEX-2-328	AEXB-2-328
.327-.348	8.31-8.84	AEX-2-344	AEXB-2-344
.342-.363	8.69-9.22	AEX-2-359	AEXB-2-359
.358-.379	9.09-9.63	AEX-2-375	AEXB-2-375
.374-.395	9.50-10.03	AEX-2-391	AEXB-2-391
.389-.410	9.88-10.41	AEX-2-406	AEXB-2-406
.405-.426	10.29-10.82	AEX-2-422	AEXB-2-422
.420-.441	10.67-11.20	AEX-2-438	AEXB-2-438
.436-.457	11.07-11.61	AEX-2-453	AEXB-2-453
.452-.473	11.48-12.01	AEX-2-469	AEXB-2-469
.467-.488	11.86-12.40	AEX-2-484	AEXB-2-484
.483-.504	12.27-12.80	AEX-2-500	AEXB-2-500
.499-.520	12.67-13.21	AEX-2-516	AEXB-2-516
.514-.535	13.06-13.59	AEX-2-531	AEXB-2-531
.530-.551	13.46-14.00	AEX-2-547	AEXB-2-547
.545-.566	13.84-14.38	AEX-2-562	AEXB-2-562
.561-.582	14.25-14.78	AEX-2-578	AEXB-2-578
.577-.598	14.66-15.19	AEX-2-594	AEXB-2-594
.592-.613	15.04-15.57	AEX-2-609	AEXB-2-609
.608-.629	15.44-15.98	AEX-2-625	AEXB-2-625
.624-.645	15.85-16.38	AEX-2-641	AEXB-2-641
.639-.660	16.23-16.76	AEX-2-656	AEXB-2-656
.655-.676	16.64-17.17	AEX-2-672	AEXB-2-672
.671-.692	17.04-17.58	AEX-2-688	AEXB-2-688
.686-.707	17.42-17.96	AEX-2-703	AEXB-2-703
.702-.723	17.83-18.36	AEX-2-719	AEXB-2-719
.717-.738	18.21-18.75	AEX-2-734	AEXB-2-734
.733-.754	18.62-19.15	AEX-2-750	AEXB-2-750
.749-.770	19.02-19.56	AEX-2-766	AEXB-2-766
.764-.785	19.41-19.94	AEX-2-781	AEXB-2-781
.780-.801	19.81-20.35	AEX-2-797	AEXB-2-797
.795-.816	20.19-20.73	AEX-2-812	AEXB-2-812
.811-.832	20.60-21.13	AEX-2-828	AEXB-2-828
.827-.848	21.00-21.54	AEX-2-844	AEXB-2-844
.842-.863	21.39-21.92	AEX-2-859	AEXB-2-859
.858-.879	21.79-22.33	AEX-2-875	AEXB-2-875
.874-.895	22.20-22.73	AEX-2-891	AEXB-2-891
.889-.910	22.58-23.11	AEX-2-906	AEXB-2-906
.905-.926	22.99-23.52	AEX-2-922	AEXB-2-922
.921-.942	23.39-23.93	AEX-2-938	AEXB-2-938
.936-.957	23.77-24.31	AEX-2-953	AEXB-2-953
.952-.973	24.18-24.71	AEX-2-969	AEXB-2-969
.967-.988	24.56-25.10	AEX-2-984	AEXB-2-984
.983-1.004	24.97-25.50	AEX-2-1000	AEXB-2-1000

Shanks other than shown above are available upon request.

Standard tool specifications

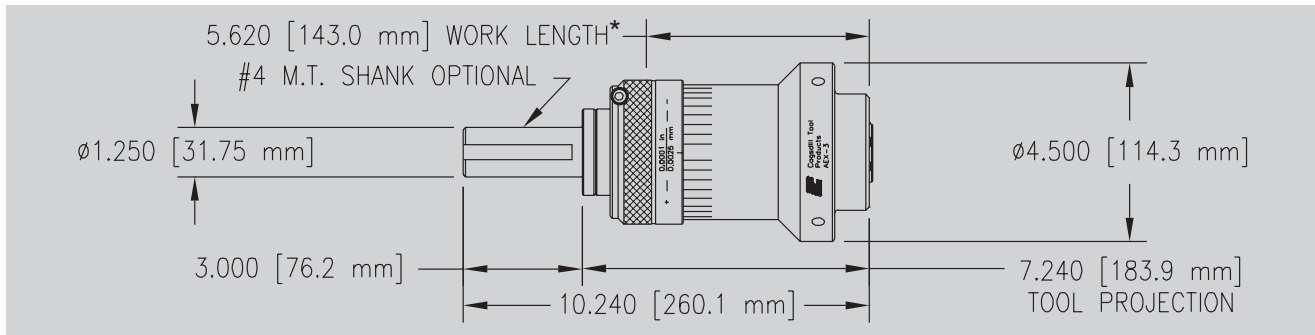

“AEX-3” SERIES ROLL-A-FINISH®TOOLS 1.016 TO 2.000 IN. (25.8 TO 50.8 MM)

DIAMETER RANGE		TOOL NUMBER	
INCHES	MM	MACHINE-FEED (NO HELIX)	BOTTOMING (NO HELIX)
.999-1.020	25.37-25.91	AEX-3-1016	AEXB-3-1016
1.014-1.035	25.76-26.29	AEX-3-1031	AEXB-3-1031
1.030-1.051	26.16-26.70	AEX-3-1047	AEXB-3-1047
1.045-1.066	26.54-27.08	AEX-3-1062	AEXB-3-1062
1.061-1.082	26.95-27.48	AEX-3-1078	AEXB-3-1078
1.077-1.098	27.36-27.89	AEX-3-1094	AEXB-3-1094
1.092-1.113	27.74-28.27	AEX-3-1109	AEXB-3-1109
1.108-1.129	28.14-28.68	AEX-3-1125	AEXB-3-1125
1.124-1.145	28.55-29.08	AEX-3-1141	AEXB-3-1141
1.139-1.160	28.93-29.46	AEX-3-1156	AEXB-3-1156
1.155-1.176	29.34-29.87	AEX-3-1172	AEXB-3-1172
1.170-1.191	29.72-30.25	AEX-3-1188	AEXB-3-1188
1.186-1.207	30.12-30.66	AEX-3-1203	AEXB-3-1203
1.202-1.223	30.53-31.06	AEX-3-1219	AEXB-3-1219
1.217-1.238	30.91-31.45	AEX-3-1234	AEXB-3-1234
1.233-1.254	31.32-31.85	AEX-3-1250	AEXB-3-1250
1.249-1.270	31.72-32.26	AEX-3-1266	AEXB-3-1266
1.264-1.285	32.11-32.69	AEX-3-1281	AEXB-3-1281
1.280-1.301	32.51-33.05	AEX-3-1297	AEXB-3-1297
1.295-1.316	32.89-33.43	AEX-3-1312	AEXB-3-1312
1.311-1.332	33.30-33.83	AEX-3-1328	AEXB-3-1328
1.327-1.348	33.71-34.24	AEX-3-1344	AEXB-3-1344
1.342-1.363	34.09-34.62	AEX-3-1359	AEXB-3-1359
1.358-1.379	34.49-35.03	AEX-3-1375	AEXB-3-1375
1.374-1.395	34.90-35.43	AEX-3-1391	AEXB-3-1391
1.389-1.410	35.28-35.81	AEX-3-1406	AEXB-3-1406
1.405-1.426	35.69-36.22	AEX-3-1422	AEXB-3-1422
1.420-1.441	36.07-36.60	AEX-3-1438	AEXB-3-1438
1.436-1.457	36.47-37.01	AEX-3-1453	AEXB-3-1453
1.452-1.473	36.88-37.41	AEX-3-1469	AEXB-3-1469
1.467-1.488	37.26-37.80	AEX-3-1484	AEXB-3-1484
1.483-1.504	37.67-38.20	AEX-3-1500	AEXB-3-1500
1.499-1.520	38.07-38.61	AEX-3-1516	AEXB-3-1516
1.514-1.535	38.46-38.99	AEX-3-1531	AEXB-3-1531
1.530-1.551	38.86-39.40	AEX-3-1547	AEXB-3-1547
1.545-1.566	39.24-39.78	AEX-3-1562	AEXB-3-1562
1.561-1.582	39.65-40.18	AEX-3-1578	AEXB-3-1578
1.577-1.598	40.06-40.59	AEX-3-1594	AEXB-3-1594
1.592-1.613	40.44-40.97	AEX-3-1609	AEXB-3-1609
1.608-1.629	40.84-41.38	AEX-3-1625	AEXB-3-1625
1.619-1.660	41.12-42.16	AEX-3-1656	AEXB-3-1656
1.651-1.692	41.94-42.98	AEX-3-1688	AEXB-3-1688
1.682-1.723	42.72-43.76	AEX-3-1719	AEXB-3-1719
1.713-1.754	43.51-44.55	AEX-3-1750	AEXB-3-1750
1.744-1.785	44.30-45.34	AEX-3-1781	AEXB-3-1781
1.775-1.816	45.09-46.13	AEX-3-1812	AEXB-3-1812
1.807-1.848	45.90-46.94	AEX-3-1844	AEXB-3-1844
1.838-1.879	46.69-47.73	AEX-3-1875	AEXB-3-1875
1.869-1.910	47.47-48.51	AEX-3-1906	AEXB-3-1906
1.901-1.942	48.29-49.33	AEX-3-1938	AEXB-3-1938
1.932-1.973	49.07-50.11	AEX-3-1969	AEXB-3-1969
1.963-2.004	49.86-50.90	AEX-3-2000	AEXB-3-2000

*Work length for nominal sizes from AEX-3-1719 through AEX-3-2000 is 3.938 in. (100mm).

Shanks other than shown above are available upon request.